

# Forklift Safety Guide

---

STATE OF WASHINGTON

Learning the safe way to operate  
a forklift may save your life





# Forklift Safety Guide

STATE OF WASHINGTON

DOSH  
Services

A Mission  
to Accomplish:

Save Lives.

Prevent Injuries and Illnesses.

Protect the Safety and Health  
of Washington's  
Workers.



The Department of Labor and Industries, Division of Occupational Safety and Health (DOSH), administers the Washington Industrial Safety and Health Act (WISHA). DOSH is responsible for workplace safety and health.





# Come to the Source!

Information on Safety and Health Standards, Ergonomics, WISHA Guidelines, Hazard Alerts, Training Workshops, Proposed Rule Changes, Safety and Health Videos.

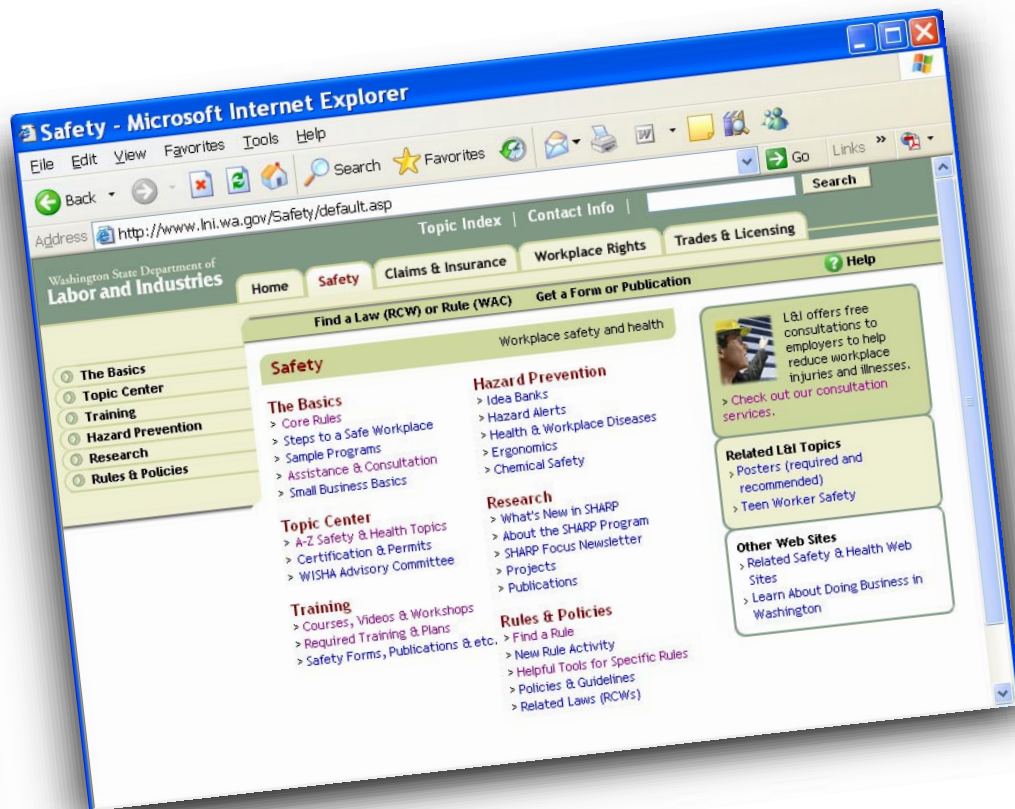

Labor & Industries' Safety web site has the Answers.

Point and Click to Thousands of Pages of Valuable Information.

[www.LNI.wa.gov/safety](http://www.LNI.wa.gov/safety)

You can print additional copies of this publication and others, directly from the web site. Large PDF files should be printed a few pages at a time.



# Forklift Safety Guide

---

## Table of Contents

Additional Resources .....	ii
Introduction.....	1
How This Book Can Help Prevent Forklift Accidents .....	2
Types of Forklifts.....	3
Forklift Operators Must be Trained .....	6
How a Forklift Works.....	8
Safely Using a Forklift.....	13
Driving indoors and Other Hazardous Locations.....	21
Maintenance of Forklifts .....	25
Summary .....	26

## Appendices

Operator's Daily Checklist .....	A
Forklift Training Facts (IPUB 417-031-000).....	31

# Additional Resources

---

## Web Site

DOSH's web site is located at [www.LNI.wa.gov/safety](http://www.LNI.wa.gov/safety). The web site provides regulations, policies, news, and additional resources. In addition, the site provides an e-mail feature that allows the user to ask questions and receive a reply.

## Safety and Health Video Library

Call 1-800-574-9881 for information on getting safety and health videos.

## Consultation Services

L&I's regional offices offer safety consultation services for employers throughout the state. Call the office nearest your workplace for more information.

Everett	(425) 290-1431
Seattle	(206) 515-2837
Tacoma	(253) 596-3917
Tumwater	(360) 902-5472
E. Wenatchee	(509) 886-6570
Spokane	(509) 324-2543

## Other Resources

- OSHA Manuals on Forklift Safety
- OSHA Sample Daily checklists for Powered Industrial Trucks, available at [http://www.osha.gov/dcsp/ote/trng-materials/pit/daily\\_pit\\_checklist.html](http://www.osha.gov/dcsp/ote/trng-materials/pit/daily_pit_checklist.html)
- Equipment and industry magazines and catalogs



# Introduction

A forklift is a powerful tool that allows one person to precisely lift and place large heavy loads with little effort. Using a tool such as a forklift, cart or hand truck instead of lifting and carrying items by hand can reduce the risk that you will suffer a back injury.



However, there is great risk of injury or death when a forklift operator:

- has not been trained in the principles of physics that allows a forklift to lift heavy loads,
- is not familiar with how a particular forklift operates,
- operates the forklift carelessly, or
- uses a forklift that is not safe due to malfunctioning, or missing parts.

Every year nearly 100 workers are killed and 20,000 are seriously injured in forklift mishaps. According to the National Traumatic Occupational Fatalities (NTOF) Surveillance System, 1530 workers died from forklift related accidents between 1980 and 2001. The top four types of incidents as a percent of the total forklift related deaths are:

Type of Incident	% of total victims
The forklift overturns	22%
A worker on foot is struck by the forklift	20%
A person is crushed by a forklift	16%
A person falls from a forklift	9%

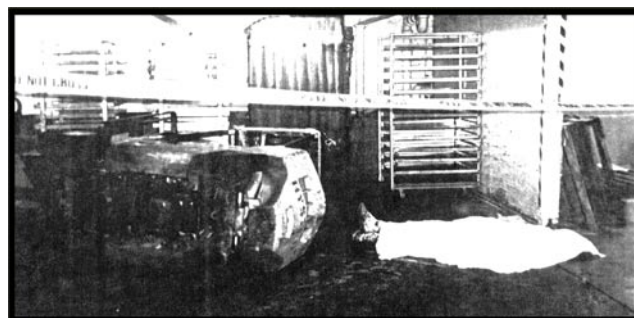

A forklift operator was struck and killed by the overhead guard when he attempted to jump as the forklift overturned.

# How this Book Can Help Prevent Forklift Accidents

This book has general information about:

- the kinds of forklifts commonly available
- the principles of physics that allow a forklift to lift and move heavy loads safely
- forklift operator training requirements
- some basic operator safety rules
- hazardous locations where carbon monoxide is a problem or a special forklift is needed
- safety while servicing a forklift.

**This book is not designed to substitute for operator training in the operation of specific forklifts in a specific workplace as required by DOSH regulations.**



Whenever you see this symbol in the book, it means that failure to follow the instructions can result in serious injury or death.

## WISHA standards that regulate forklifts

Safety rules developed under the Washington Industrial Safety and Health Act (WISHA) regulate the safe use of forklifts and other “powered industrial trucks” in Washington workplaces. You can find these rules in:

Forklifts and other Powered Industrial Trucks	WAC 296-863
Construction Standard	WAC 296-155-615(3)
Agriculture Standard	WAC 296-307-520
Longshore, Stevedore and Related Waterfront Standard	WAC 296-56-60077

You can get a copy of these rules on the DOSH web site: [www.lni.wa.gov/safety](http://www.lni.wa.gov/safety) or by calling the L&I office nearest you.

# Types of Forklifts

A forklift is a type of “powered industrial truck” covered by DOSH standards. Like other powered industrial trucks, its purpose is to move, carry, push, pull, and lift a material load then stack it or place it in a storage rack (tier). Forklifts come in many sizes and capacities. They can be powered by batteries, propane, gasoline, or diesel fuel. Some are designed to be used in a hazardous location or atmosphere where an ordinary forklift might cause a fire or explosion.

Powered industrial trucks are classified into seven types based on their characteristics. On the next pages are some illustrations of common forklifts that fit these classes.

Class	Type
Class 1	Electric Motor, Rider, Counter-Balanced Trucks (solid and pneumatic tires)
Class 2	Electric Motor Narrow Aisle Trucks (solid tires)
Class 3	Electric Motor Hand Trucks or Hand/Rider Trucks (solid tires)
Class 4	Internal Combustion Engine Trucks (solid tires)
Class 5	Internal Combustion Engine Trucks (pneumatic tires)
Class 6	Electric and Internal Combustion Engine Tractors (solid and pneumatic tires). There are no forklifts in this class.
Class 7	Rough Terrain Forklift Trucks (pneumatic tires)

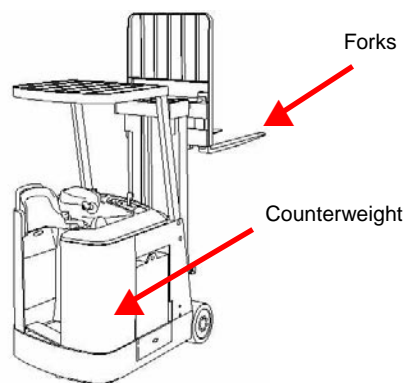

Stand Up Rider: Forklift has a counterbalance weight in the body. The rider stands inside the body of the forklift.

Example of:  
Class 1 Electric Rider Counterbalanced Truck

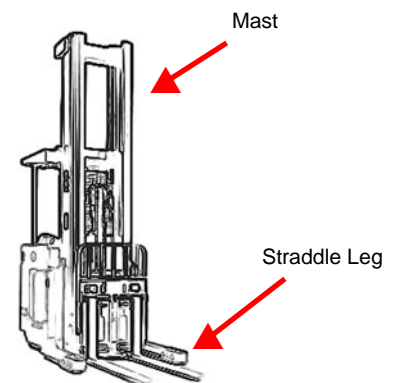

Stand Up Rider Narrow Aisle: The forklift has straddle legs on both sides of the forks to provide stability in the absence of a counterweight in the body.

Example of: Class 2 Electric Narrow Aisle Truck

# Types of Forklifts (continued)

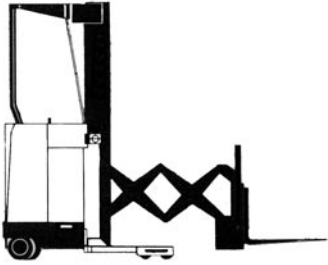

Stand Up Reach Rider Narrow Aisle: Forks extend in and out as well as up, down, and tilt.

Example of:  
Class 2 Electric Narrow Aisle Truck

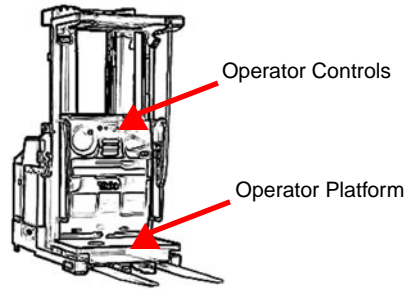

Stand Up Rider Order Picker: The operator stands on a platform in front and along with the controls is transported to the elevated location.

Example of:  
Class 2 Electric Narrow Aisle Truck

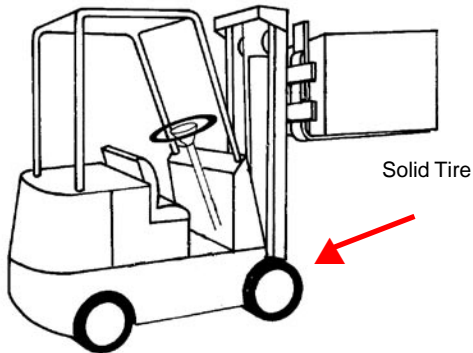

Sit Down Rider: The forklift has a counterbalance in the rear.

Example of:  
Class 1 Truck if electric powered.  
Class 4 Truck if internal combustion (gas, diesel or LP gas) powered with solid tires.  
Class 5 Truck if internal combustion powered with pneumatic tires.

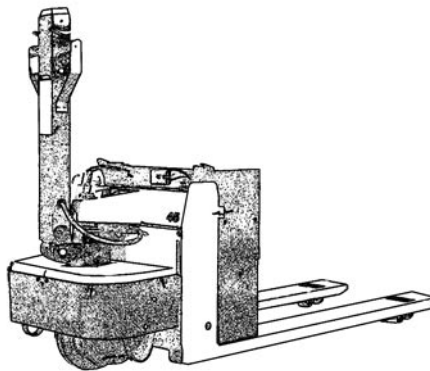

Motorized Hand Pallet Jack: A low lift (ground level) unit has forks or a platform. Some models allow the operator to stand on the back. Others, like this one, are walked.

A high lift version has a mast and straddle legs.

Example of:  
Class 3 Electric Motor Hand/Rider Truck

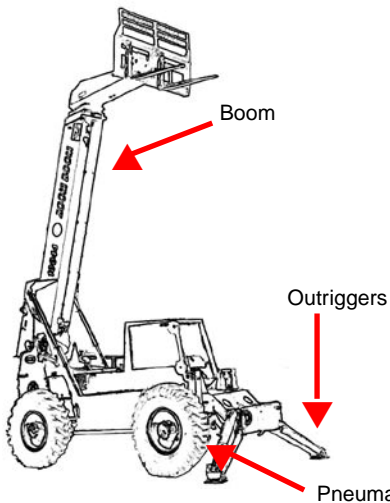

Rough Terrain Reach Forklift: The forklift has large pneumatic tires. It has a boom which raises and extends. It has outriggers at the front to stabilize the forklift on soft or uneven ground.

A rough terrain forklift might also resemble a sit down rider as shown above. It is bigger with large pneumatic tires and a large mast with large forks. It is powered by an internal combustion engine.

Example of:  
Class 7 Rough Terrain Forklift Truck

# Types of Forklifts (continued)

Sometimes special attachments are installed onto the forks to extend the reach, clamp a barrel, act as hoist, lift odd-shaped items like a roll of carpet or even lift people.



Jib Crane Attachment



Hoist Attachment



Drum Grabber Attachment



Carpet Lifting Attachment



Personnel Platform



Using an unapproved attachment could alter the forklift's lifting and balance characteristics and lead to a forklift overturning.

Whenever an attachment is used that could affect the capacity or safe operation of a forklift, its use must be approved by the forklift manufacturer. The employer must mark the forklift to show the new weight with attachment. The maximum capacity at the highest elevation must also be shown.

# Forklift Operators must be trained



An untrained operator of a forklift can be as dangerous as an unlicensed operator of a motor vehicle.

DOSH regulations require that the employer ensure that a forklift operator is competent to operate the forklift he or she is assigned to use. The employer must document operator training and an evaluation of the operator's performance while using the forklift.

## Training has three parts:

- formal instruction such as a lecture, discussion, interactive computer learning, videotape and or written material (can be taken anywhere);
- practical training which includes hands-on demonstrations by the trainer and exercises by the trainee (on the model of forklift the worker will use); and
- an evaluation of the effectiveness of the training by observing the operator's performance while doing actual work using the forklift. This evaluation must be repeated at least once every three years (must be at workplace).

Refresher training must be given if the operator has been involved in an accident, near miss or unsafe operations. Also, if an operator is assigned to a new type of forklift or if workplace conditions change that could affect safety, then refresher training is required.



Forklift operators must be trained in the operating instructions, warnings and precautions for the types of forklifts they will be authorized to use.

# Forklift Operators must be trained (continued)

The topics listed in the table below must be covered when training a forklift operator. If a specific topic does not apply to the forklift in the employer's workplace, covering it is optional.

Topics related to powered industrial trucks	Topics related to your workplace
Operating instructions	Surface conditions where the PIT will be operated
Warnings and precautions for the types of PIT the operator will be authorized to operate	Composition of loads to be carried and load stability
Differences between the PIT and the automobile	Load manipulation, stacking, and un-stacking
PIT controls and instrumentation: Where they are located, what they do, and how they work	Pedestrian traffic in areas where the PIT will be operated
Engine or motor operation	Narrow aisles and other restricted places where the PIT will be operated
Steering and maneuvering	Use of door opening and closing devices
Visibility (including restrictions due to loading)	Hazardous (classified) locations where the PIT will be operated
Fork and attachment adaptation, operation, and use limitations	Ramps and other sloped surfaces that could affect the PITs stability
PIT capacity	Closed environments and other areas where insufficient ventilation or poor PIT maintenance could cause a buildup of carbon monoxide or diesel exhaust
PIT stability	Other unique or potentially hazardous environmental conditions in the workplace that could affect safe operation
Any PIT inspection and maintenance that the operator will be required to perform	
Refueling	
Charging and recharging of batteries	
Operating limitations	
Any other operating instructions, warnings, or precautions listed in the operator's manual for the types of PIT that the employee is being trained to operate	

**Qualified Trainers** – The employer or any other person the employer chooses who has the knowledge, training and experience to train and evaluate forklift operators can do this training and evaluation. The trainee can only operate the forklift when directly supervised by such a person and when this would not endanger anyone.

**Documenting Training** – If the operator had previous forklift training, the employer must document that the training covered the required topics described above. The operator must have been evaluated in the current workplace within the last three years.

**Training and Evaluation Records** – The employer must keep a record that shows that each forklift operator has been trained. The record includes the name of the operator, date of training, date of evaluation and the name of the person(s) giving the training and evaluation.

# How a Forklift Works

## Driving a forklift is different than driving a car

In a car or truck the front wheels steer the vehicle. A forklift has the steering wheels in the rear. The rear end of the forklift swings in a circle around the front wheels that support most of the load. The operator must check that there is room for the rear end to swing when making turns. This clearance can be maintained in your workplace by permanently marking aisles with painted lines or arranging storage racks in a way that creates obvious aisles for travel. However, these marked aisles will only be effective if you keep them clear of stored materials, which can gradually encroach as space is needed.



Mark aisles to help keep adequate clearance for forklifts.

A forklift is not as responsive as a car when turning the steering wheel. Rear steering makes it difficult to stop a forklift quickly or swerve and still maintain control. It is important, then not to drive a forklift fast or round corners quickly.



Driving with the load downhill can result in loss of the load and control of the forklift.

If you drive a forklift on an incline, you must keep the load on the uphill side. Otherwise, you may have no weight on the wheels that steer and can lose control! The load could also fall off or cause the forklift to tip.

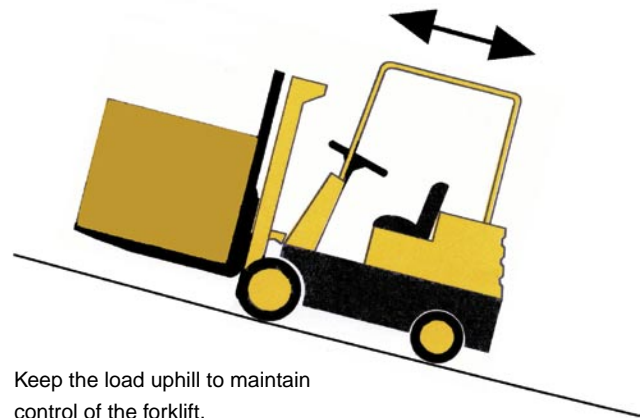

Keep the load uphill to maintain control of the forklift.



A backrest extension keeps the load from falling rearward.

Often a large forklift load obstructs the driver's view in one direction. It may be necessary to travel long distances with the load to the rear (in reverse for most forklifts). Use extra caution when traveling in reverse.

## Forklift safety features

A backrest extension on the forks prevents part of the load from falling rearward toward the operator. This is required when loads are lifted high and the type of load would allow all or part of it to fall to the rear under conditions such as acceleration, sudden stops or driving on an uneven surface.



# How a Forklift Works (continued)



An overhead guard can deflect objects falling from above.



Wear a seat belt to keep you inside if your forklift overturns.

An overhead guard prevents an object on the forks or on a high rack from falling onto the operator while picking or placing a load at elevation. The guard is not designed to withstand the impact from a full load. It can be effective in deflecting small packages. It is required on all forklifts that can lift a load above the operator unless conditions such as clearances would not allow the forklift to be used.

Operator restraints will hold you in the seat if you strike an object or if the forklift overturns. Since 1992, forklift manufacturers have been required to equip new forklifts with operator restraints such as seat belts. Many forklift manufacturers offer restraint systems that can be retrofitted on older forklifts.

If your forklift begins to overturn, you are safest when you stay in the seat, hold on firmly, and lean in the opposite direction of the fall rather than trying to jump. Many fatal accidents happened when the operator tried to jump. As the forklift begins to tip, it will move slowly – tricking the operator into believing there is time to jump. Once the center of gravity is past the wheel line, the forklift will rapidly fall. The forklift's overhead guard will quickly pin or crush an operator who jumps.



Failure to wear a seat belt can result in the operator being thrown outside the protective cage in the event of an overturn.

If your forklift has a restraint such as a seat belt or a lap bar, you must use it.

## How forklifts safely carry and lift heavy loads

A forklift works on the principle of a cantilever. A load on a beam (the forks) supported by a fulcrum (the front wheels) is counterbalanced by a weight on the other end of the beam (the forklift body and counterweight built into it).

Whether a forklift will safely carry a load or will tip forward can be determined by comparing the “moment” of each.

Moment equals the distance from the fulcrum to the center of gravity (the point where all the weight is concentrated) times the weight.

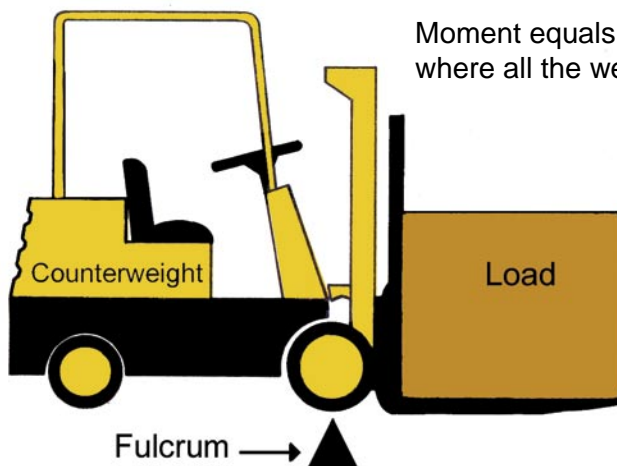

# How a Forklift Works (continued)

Example: an evenly distributed 36" wide load on the forks has a center of gravity that is 18" from the face of the forks<sup>1</sup>. If the load weighs 4000 pounds then the load moment will be (18" x 4000 lb.) = 72,000 inch-pounds.

If the "moment" of the forklift is greater than, or equal to the 72,000 inch pounds of the load then the forklift will safely carry the load.

Forklifts have a capacity plate to tell the user what loads are safe to lift. If the plate says the capacity is 30,000 pounds or less then that capacity is rated for a load with a center of gravity 24" from the face of the forks. If the forklift capacity is greater than 30,000 pounds then the label will rate the load at a 36" or 48" center of gravity since larger forklifts usually lift physically larger loads.

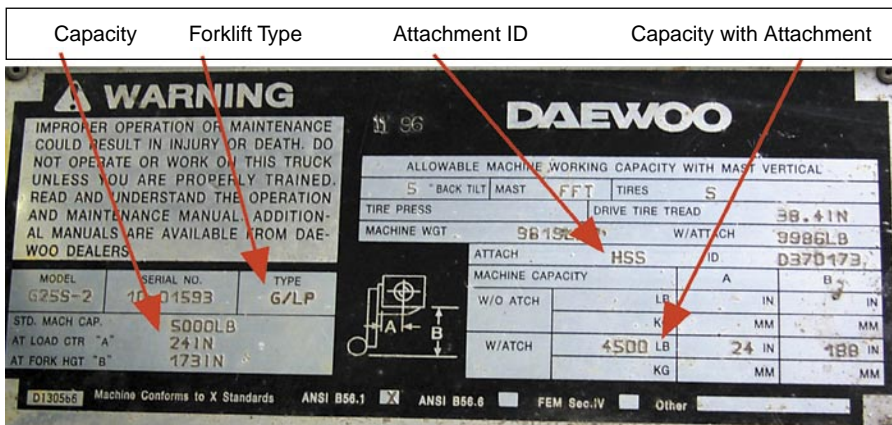

This LP Gas Forklift can safely lift 5000 lbs. 173" high with a center of gravity 24" from the face of the forks. With an attachment labeled "HSS", the safe load drops to 4500 lbs.

Using the example and capacity plate above, a forklift rated at 5000 pounds would safely lift a load with a moment of up to (24" X 5000 lb.) = 120,000 inch-pounds. In this case the load above would be safe to lift.

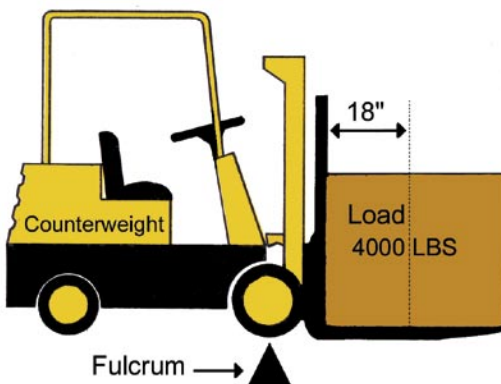

Forklift Moment = (24" X 5000 LBS) = 120,000 inch-pounds  
 Load Moment = (18" X 4000 LBS) = 72,000 inch-pounds

The load is safe to lift because load moment is less than forklift moment.

However if the 4000 pound load was 66" wide, the load moment would be (33" X 4000 lb.) = 132,000 inch-pounds which would be greater than the moment of the forklift. The forklift would tip forward.

<sup>1</sup> The fulcrum point is actually at the center of the wheel. Forklift load charts, however, are adjusted to allow measuring from the face of the forks.

# How a Forklift Works (continued)

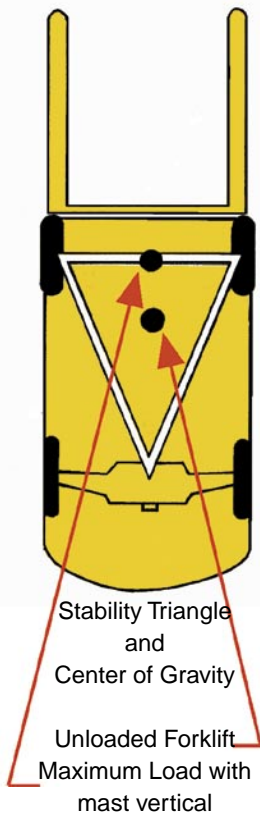

As the load is raised, it becomes possible for the forklift to fall to the side as well as tip forward. The operator must consider the center of gravity of the forklift and load together. This combined center of gravity moves as the load is moved and as the forklift travels over surfaces that are rough or inclined.

Forklifts have a “stability triangle”. The sides of the triangle as shown in the illustration are formed by the center of each front wheel and the center of the rear wheel or at the center of the axle if there are two rear wheels. A vertical line extending from the center of gravity of the vehicle-load combination must be inside of the stability triangle to prevent the forklift from tipping forward, falling sideways or dropping its load.

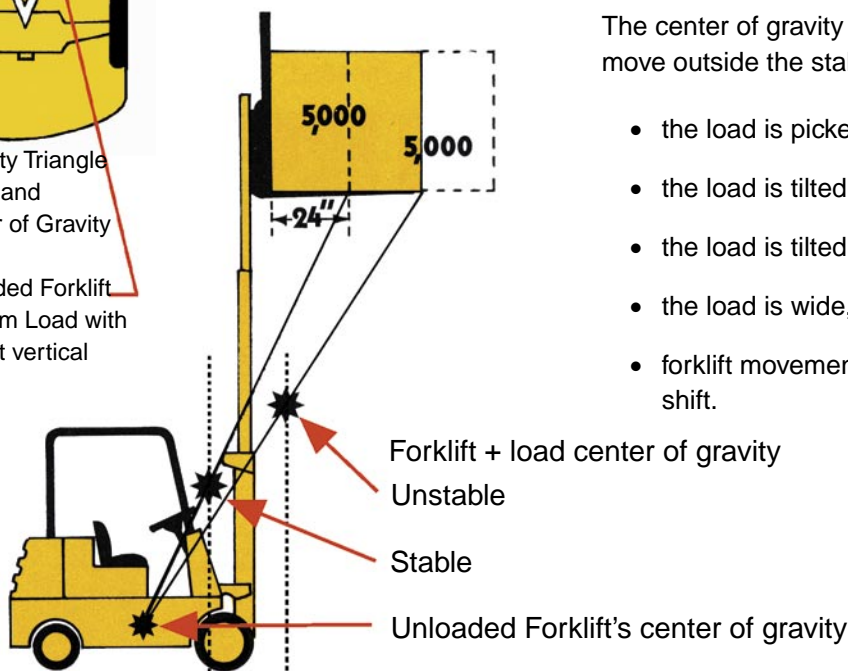

The center of gravity of the forklift-load combination can move outside the stability triangle if:

- the load is picked up on the tip of the forks,
- the load is tilted forward.
- the load is tilted too far back when raised,
- the load is wide, or
- forklift movement causes the center of gravity to shift.

These actions will have the following effects:

Action	Center of gravity moves
Tilting the load forward	Toward the front axle
Raising the load while tilted forward	
Driving on an incline with the load downhill	
Stopping forward travel or accelerating backward	
Tilting the load back	Toward the rear axle
Raising the load while tilted back	
Driving on an incline with the load uphill	
Accelerating forward or stopping backward travel	
Driving across an inclined surface	Toward the downhill side of the triangle
Driving across a rough or uneven surface	Toward the rut or low side of the triangle
Turning	Toward the side now facing the original direction of travel

# How a Forklift Works (continued)

---



This list represents operator procedures that reduce the risk of overturn, collision or loss of the load.

To prevent your forklift from tipping over, falling sideways or dropping its load:

- Make sure the load is stable and safely arranged on the forks.
- Do not tilt the forks forward except when picking up or depositing a load.
- Tilt the load backward only enough to stabilize the load.
- Keep the load low just above the pavement with forks tilted back when traveling.
- Cross railroad tracks diagonally when possible.
- Enter elevators squarely.
- Keep the load uphill when going up or down an incline.
- Drive at a speed that will allow you to stop safely within the stability triangle.
- Slow down on wet or slippery surfaces.
- Slow down to make turns.
- Avoid driving over loose objects or on surfaces with ruts and holes.

# Safely Using a Forklift



Failure to check that the forklift is operating properly can lead to an accident as the description below demonstrates.

## A Defective Forklift Can Kill

September 1996

A 43 year-old president of an advertising sign company was killed while using a forklift to unload steel tubing from a flatbed trailer. He was driving about 5 miles per hour beside the trailer on a concrete driveway with a 3% grade. The victim turned the forklift behind the trailer. The forklift began to turn over on its side. The victim jumped from the seat toward the driveway. The victim's head and neck were pinned to the driveway by the forklift's overhead guard. An inspection of the forklift revealed that the right-side rear axle stop was damaged before the accident and was not restricting forklift lateral sway as it turned. Also, slack in the steering mechanism required the operator to turn the steering wheel slightly more than half a revolution before the wheels started to turn. The forklift was not equipped with a seat belt.

- From NIOSH Alert 2000-112.

## Pre-use inspection

The forklift must be checked for defects daily — usually by the operator before beginning a shift. Even if you operate a forklift safely, a defect can cause or contribute to a serious accident. Some things to look for are:

- Is the horn working? Sound the horn at intersections and wherever vision is obstructed.
  - Are there hydraulic leaks in the mast or elsewhere? These could cause slipping hazards or lead to hydraulic failure.
  - Are fuel connections tight and battery terminals covered? Dropping a piece of metal across battery terminals can cause an explosion.
  - Is there a lot of lint, grease, oil or other material on the forklift that could catch on fire?
  - Do sparks or flames come out from the exhaust system?
  - Does the engine show signs of overheating?
  - Are tires at proper pressure and free of damage? A tire with low pressure or a tire failure can cause a forklift to tip or fall when a load is high.
  - Do all controls such as lift, lower, and tilt work smoothly? Are they labeled?
  - Is there any deformation or cracks in the forks, mast, overhead guard, or backrest?
- 
- Are lights operating if used at night or in dark locations?
  - Is steering responsive? A lot of play or hard steering will reduce your control.
  - Do brakes stop smoothly and reliably? Sudden stops can cause tipping.
  - Does the parking brake hold the forklift on an incline?
  - Are seat belts (if equipped) working and accessible?
  - Is the load capacity plate readable?

Any defects that would affect safety must be corrected before the forklift is returned to service.

Appendix A is a sample operator pre-use inspection checklist.

# Safely Using a Forklift

## Surface Condition

The surface a forklift operates on can cause serious safety problems. Loose objects, bumps, or depressions can cause you to lose control of steering, bring you to a sudden unplanned stop or cause you to drop your load. A soft dirt surface can cause a wheel to sink and destabilize an elevated load and the forklift.

Any surface a forklift drives on must be able to support the forklift and its load with a safety factor of four. If a 7,000 pound forklift is carrying a 3,000 pound load then the floor must be able to support 40,000 pounds. Remember that nearly the full weight of the load plus a part of the weight of the forklift may be centered near a single wheel.

Wet, oily or icy surfaces should be avoided. Clean them up as soon as possible.



## Traveling

The basic rule for traveling is that you maintain control of your forklift at all times. Other rules include:

- Operate a forklift only while in the seat or operator's station. Never start it or operate the controls while standing beside the forklift.
- Never allow passengers unless the forklift was designed for a passenger.
- Do not put any part of your body between the uprights of the mast or when traveling, outside of the forklift frame.
- Always look in the direction of travel and keep a clear view of the travel path. Travel in reverse if the load blocks your view.
- Always observe posted speed limits at your workplace. A forklift should not be driven faster than a quick walking pace.
- Keep a distance of at least three forklift lengths between you and any forklift traveling in front of you.
- Do not pass a forklift traveling in the same direction if it is at a blind spot, intersection or other dangerous location.
- Never drive a forklift up to anyone in front of a bench or other fixed object.
- Never allow anyone to walk or stand under the elevated forks – even if the forks are not carrying a load.
- Check that there is adequate clearance under beams, lights, sprinklers, and pipes for the forklift and load to pass.
- Never engage in stunt driving or horseplay.

# Safely Using a Forklift (continued)

## Driving onto trucks, trailers, and railroad cars



Failure to secure the truck or trailer with blocks can cause the trailer to move resulting in the forklift falling between the trailer and the dock.

Forklifts are often driven onto trucks, trailers, or railroad cars over a dock board (also known as a bridge plate) at loading docks. If the truck, trailer or car is not secured to the dock or otherwise chocked, it can move over time. The dock board can then fall between the trailer and the dock as the forklift crosses it.

You can secure wheel chocks with chain at each loading dock bay and tell truck drivers that they must place them in front of the rear wheels. Another way of securing the trailer is to use a vehicle restraint system mounted to the dock that clamps onto a bar below the trailer as it backs into place. This system will signal when the restraint is engaged or if there is a problem.

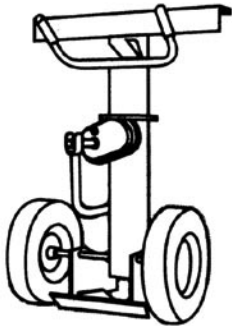

Trailer Jack

The pavement at some loading docks slopes downhill toward the loading dock. This is not a substitute for chocking wheels.

Sometimes a trailer is left at a loading dock without the tractor attached. Use trailer jacks to prevent the trailer from up-ending when a forklift drives to the front of the trailer to load or unload.



Chock the rear wheel of trucks and trailers to prevent movement away from the dock. Notice the sign tells drivers to chock the wheels.



Dock mounted vehicle restraint clamps to a bar under the truck.

# Safely Using a Forklift (continued)



An unsecured dock plate can move over time resulting in a sudden stop of the forklift and loss of the load as the wheels lodge in the space between the dock and the truck bed.

A portable dock board must be secured in place to prevent it from moving. Some boards have pins that are inserted into the sides and project below the board. This prevents the board from moving toward the dock or toward the trailer. To prevent crushed fingers and make for safe handling, a portable dock board must also have handholds or lugs that allow the forklift to pick it up.

Keep a safe distance from the edge of a loading dock or a ramp. The edge must be painted yellow or with alternating yellow and black diagonal stripes to warn of both the fall hazard and the potential to be crushed by a trailer backing into the dock. Some loading docks have a bull rail that prevents a wheel from slipping off the sides of ramps or edges of the dock where a forklift would not have to cross to enter a trailer.

Any part of the dock edge that is four feet or more above the adjacent surface must have a standard guardrail. Removable rails (such as chain rails) and posts can be used at the place where trucks or trailers will be loaded.

Use rail mounted chocks to secure a railroad car. Also, prevent anyone from moving the rail car while the forklift is working. A blue sign with the word "STOP" attached to the track is one way of signaling that the car must not be moved. A special attachment must be used if a forklift is used to open a rail car door.

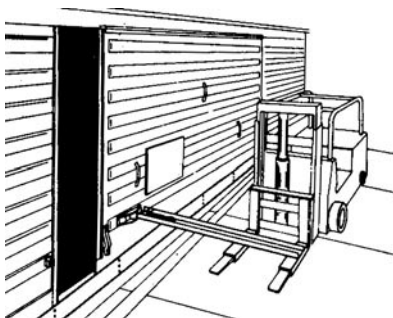

Forklift attachment used to open railroad car doors.



A projection below the surface prevents the dock board from shifting off its support.



A bull rail at an unused edge of a dock reduces the risk of a forklift wheel slipping off.

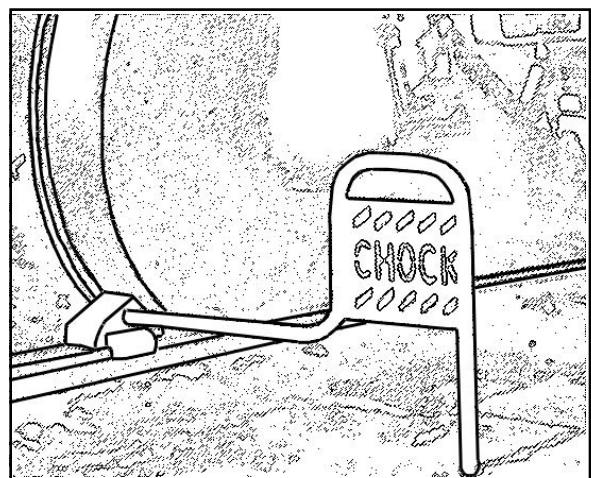

A railroad car wheel chock with a sign prevents car movement and warns that the wheel is chocked.



# Safely Using a Forklift (continued)

## Loading and unloading the forklift

Check the load before you pick it up.

- Is it stable or will parts slide or fall during transit? Secure it as necessary. The illustrations below show some common pallet stacking patterns.

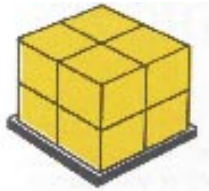

Block

The most common.  
The upper level may be unstable if not encircled with wire or strapping.

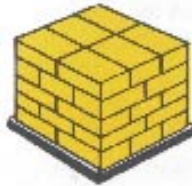

Brick

Containers are interlocked by turning each level 90 degrees.

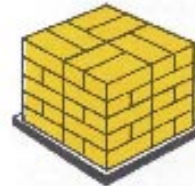

Pinwheel

Used where brick pattern is unstable.

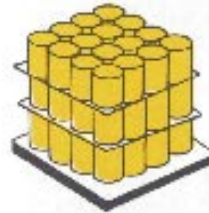

Irregular Stacking Patterns

Wood strips, plywood or heavy cardboard between layers can help stabilize castings, bags, and other irregular shapes.

- Do the dimensions and weight of the load fall within the capacity rating of the forklift at the highest elevation and extension you will handle the load? If not, can you break the load into smaller parts?

When you pick up the load:

- Move squarely into position in front of the load.
- Position the forks wide apart to keep the load balanced.
- Drive the forks fully under the load.
- Tilt the mast backward slightly to stabilize the load and lift.

Check the destination before you place the load.

- Is the destination flat and stable — or, will the load rock, tilt or lean?
- Never place heavy loads on top of light loads.
- Observe maximum stacking quantities and orientation if printed on cartons.
- Do you know the load bearing capacity of your rack or storage loft destination?
- Are rack legs or support members bent or disconnected? The load bearing capacity of a damaged rack is unknown! Wait until the damaged component has been replaced before loading.

# Safely Using a Forklift (continued)

- Are racks arranged back to back with a stock behind where you will place the load? Someone may need to be in the next aisle to control access while you place the load.
- Are wooden stringers or decking laid between front and rear rack beams in good condition?
- If you are stacking, are other pallets in the stack in good condition and capable of supporting the load in addition to what they are already supporting?



Check that wood stringers or decking in racks are in good condition. They may support the load if the pallet is not properly placed on both front and rear rails.

When you place the load at its destination:

- Move squarely into position in front of the rack or stack where the load will be placed.
- When ready to place the load, tilt the mast to level. Only tilt forward when the load is over the spot where it will be placed.
- Lower the forks and back away.
- Visually verify that the load is stable.

## Leaving a forklift unattended

A forklift is considered to be unattended when it is not in view of the operator or if it is in view, the operator is 25 feet or more away. If you leave a forklift unattended, lower the forks to the ground. Set the controls to neutral, turn off the power, and set the brakes. If the forklift is on an incline, block the wheels.

If you dismount a forklift and stay within 25 feet, you must at least lower the forks to the ground, set the controls to neutral and set the brakes.



Lifting or lowering a person on forks or a pallet can result in a fall injury or fingers caught in moving parts of the mast.

## Lifting and lowering people

Never allow anyone to be lifted while standing on the forks or on a pallet lifted by the forks! If you want to use a forklift to raise an employee to an elevated position, use a platform or structure specifically built for this purpose that meets these conditions:

- The platform must have standard guardrails which include a top rail 36" to 42" above the platform (39" to 45" on a construction site), midrail and toeboard. It must also prevent contact with chains and shear points on the mast. See the illustration for an example.



Never stand on the forks or a pallet to work at an elevated level.

# Safely Using a Forklift (continued)

## Fall from Forklift

September 6, 1995

A 47 year-old male assistant warehouse manager was fatally injured while working with a forklift operator to pull tires from a storage rack. The two workers placed a wooden pallet on the forks of the forklift and the victim then stood on the pallet. The operator raised the forks and victim 16 feet above a concrete floor. The victim had placed a few tires on the pallet when the operator noticed that the pallet was becoming unstable. The victim lost his balance and fell, striking his head on the floor.  
- From NIOSH Alert 2000-112

- The platform must be securely attached to the forks such as by a clamp or chain.
- Check with the forklift manufacturer to verify that the hydraulic system will not allow the lift mechanism to drop faster than 135 feet per minute in the event of a system failure. Identify the forklift as approved for use with the platform.
- Lock or secure the tilt control to prevent the boom from tilting.
- A forklift operator must be at the normal operating position when lifting and lowering the platform. The operator must be near the forklift while a worker is elevated.
- Except to inch or maneuver at low speeds, do not move the forklift between two points when a worker is on the platform.

Order picker forklifts are designed to allow the operator to be lifted along with the controls to an elevated location. However, if the operator station does not have standard guardrails on all open sides, then the operator must wear a full body harness with lanyard attached to a manufacturer approved anchor.



These practices are designed to prevent explosion of flammable vapors due to spark or collision with unprotected fuel tanks.

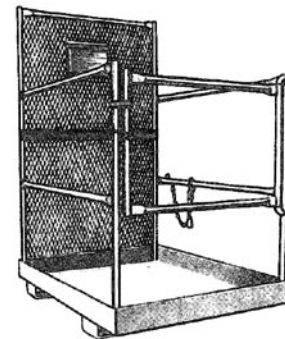

Forklift work platform has standard guardrails and a screen to prevent contact with moving parts of the mast. A chain secures the platform to the mast.

## Fueling/charging

When refueling or charging batteries, observe the following precautions:

- Do not smoke or allow any open flames or spark /arc generating equipment in the refueling / charging area.
- Make sure there is adequate ventilation to disburse fumes.
- Make sure there is a fire extinguisher nearby.
- Make sure there is a barrier that protects the pump or charger against vehicle damage.



The operator of an order picker type forklift must wear a safety harness to protect against the fall hazard at an elevated location.

# Safely Using a Forklift (continued)

## Liquid Petroleum Gas (LPG) forklifts

- LPG gas is very cold. Wear gloves when changing LPG tanks. Check for leaks before operating.

## Gasoline or diesel forklifts

- Turn the engine “OFF” and apply the hand brake before gasoline or diesel refueling.
- Clean up any spilled fuel before restarting the engine.

## Battery operated forklifts

- When charging batteries, keep the battery vent caps in place to prevent electrolyte spray. (Check that the vent caps are not plugged.)
- Keep the battery compartment open to dissipate heat.
- Keep tools and other metal objects away from the top of the battery to prevent an arc or explosion due to short circuited terminals.
- When adding fluid to the battery, wear safety glasses and a face shield for protection against electrolyte splash or spray.
- Battery charging areas must have a way to flush and neutralize spilled electrolyte.
- Do not attempt to remove a battery from the forklift unless you have been trained and the charging station is equipped with a hoist designed for this purpose.
- If you do any service to a battery beyond routine charging the employer must supply an eyewash station that can be reached within 10 seconds and that is capable of providing .4 gallons of water per minute for 15 minutes.



Propane tank used to refill the forklift LPG tank is protected against vehicle damage by heavy posts.



An eyewash or eyewash with shower must be available when doing battery service beyond routine charging.

# Driving Indoors and In Other Enclosed Locations



## Carbon monoxide hazard

Internal combustion engines produce carbon monoxide. This gas can rapidly build up in any indoor area. People can be overcome without even realizing they are being exposed. Confusion, headache, dizziness, fatigue, and weakness may set in too quickly for victims to save themselves. Carbon monoxide poisoning can cause permanent brain damage, including changes in personality and memory. Once inhaled, carbon monoxide decreases the ability of the blood to carry oxygen to the brain and other vital organs. Even low levels of carbon monoxide can set off chest pains and heart attacks in people with coronary artery disease.

WISHA standards (WAC 296-841) set the maximum allowable exposure to carbon monoxide. Gasoline powered forklifts should not be used indoors. Propane forklifts also produce carbon monoxide and must be regularly inspected and maintained. If you are concerned about the exposure level in an enclosed area where a forklift operates, contact a qualified industrial hygienist to make measurements and recommendations to improve ventilation.



Internal combustion engine forklifts can cause carbon monoxide poisoning when used indoors if the engine is not kept tuned and the area well ventilated.

# Driving Indoors and In Other Enclosed Locations (continued)

Operating a forklift in an environment where chemicals or other substances are present can be hazardous. Use only forklifts that are designed for operations under those conditions.

To select the appropriate forklift, you must know the type of location (Class), the name of the chemical or substance and how likely it is that the hazardous condition would be present (Division).

## Terms

A Class I location contains flammable gases or vapors.

A Class II location contains combustible dust.

A Class III location contains easily ignited fibers.

An Unclassified location is a general storage, commercial or industrial location without the hazard conditions described above.

A Division I location has a high potential for the hazard to be present.

A Division II location has a lower potential for the hazard to develop.

## Use the table on page 23 to select a safe forklift.

1. Look in the first column of the table for the hazard class of the material.
2. Find the row that has the chemical or substance handled.
3. Choose the second or third column based on the division that represents the exposure condition.
4. To interpret the hazard designations listed in the second or third column, refer to the table on page 24.

If you Work in an Area Where These are Present:	Then Use this Type of Forklift (Designations on Page 24).	
Hazard Classification	Acceptable Forklift Designations	
<b>Class 1</b> Flammable gases or vapors are or may be present in quantities sufficient for explosion or ignition.	<b>Division I</b> Condition exists continuously, intermittently, or periodically under normal operating conditions.	<b>Division II</b> Condition may occur accidentally e.g., puncture of a storage drum.
Acetylene, Acetaldehyde, Butadiene, Cyclopropane, Diethyl ether, Ethylene, Ethylene oxide, Isoprene, Propylene oxide, Hydrogen (or gases or vapors equivalent in hazard to hydrogen, such as manufactured gas), Unsymmetrical dimethyl hydrazine (UDMH).	Forklift use prohibited	DY, EE, EX (also DS, ES, GS, LPS) if the only exposure is sealed containers or liquefied or compressed gases in containers
Acetone, Acrylonitrile, Alcohol, Ammonia, Benzene, Bensol, Butane, Ethylene dichloride, Gasoline, Hexane, Lacquer Solvent, Natural gas, Naphtha, Propane, Propylene, Styrene, Xylenes, Vinyl acetate, Vinyl chloride	EX	DY, EE, EX (also DS, ES, GS, LPS) if the only exposure is sealed containers or liquefied or compressed gases in containers
<b>Class II</b> • Combustible dust is present	<b>Division I</b> Explosive or conductive mixture may be present under normal conditions or where equipment failure can lead to both this condition and arching or sparking.	<b>Division II</b> Explosive mixture not normally present but where deposits of dust may cause heat rise in electrical equipment.
• Aluminum, magnesium, and their commercial alloys  • Other metals of similarly hazardous characteristics	Forklift use prohibited	Forklift with electrical enclosures manufacturer approved where magnesium, aluminum or aluminum bronze may be present.
• Carbon black,  • Coal or coke dust	EX	Forklift manufacturer approved for this location.
• Other combustible dusts	EX	DY, EE, EX
<b>Class III</b> Easily ignitable fibers or flyings are present but not likely to be in suspension in quantities sufficient to ignite.	<b>Division I</b> Locations in which these materials are handled, manufactured or used.	<b>Division II</b> Locations in which these materials are stored or handled (other than manufacture)
Baled waste, Cocoa fiber, Cotton, Excelsior, Hemp, Istle, Jute, Kapok, Oakum, Sisal, Spanish moss, Synthetic fibers, Tow	DY, EE, EX	DS, DY, ES, EE, GS, LPS (Type E may continue to be used if used previously at this location.)
<b>Unclassified Locations</b> Piers and wharves inside and outside general storage, general industrial or commercial properties.	D, E, G, LP (more protective designations may also be used)	
See page 24 for forklift designations		

# Driving Indoors and In Other Enclosed Locations (continued)

## Explosion/Combustion Hazards

All forklifts have a hazard designation assigned to them that tells whether they are suitable for use in certain kinds of hazardous atmospheres. You can find the designation on the forklift's load capacity plate. The table below explains the designations.

Type	Built-in Safeguards Against Fire Hazards
D (Diesel forklift)	Minimum
DS	D + additional for fuel, exhaust and electrical systems
DY	DS + all electrical equipment enclosed
E	Minimum
ES	E + prevents sparks and limits surface temperatures
EE	ES + all electric motors and equipment completely enclosed
EX	Can be used in flammable vapor or dust atmospheres
G (Gasoline forklift)	Minimum
GS	G + additional for fuel, exhaust and electrical systems
LP	G + minimum safeguards for liquid petroleum gas
LPS	LP + additional for fuel, exhaust and electrical systems



# Maintenance of Forklifts

## “Out of Service” and Required Check Intervals

DOSH regulations require that a forklift be checked for defects the first time it is placed in service and every day that the forklift is used. If the forklift is used continuously, then it must be checked at the end of each shift.

Appendix A is a sample operator’s “Daily Forklift Safety Checklist” that can be attached to the forklift as a reminder to the operator to do this check. Some employers keep records of these daily checks.

If a forklift is found unsafe then it must be removed from service until repaired by an authorized person.

In addition, the forklift owner’s manual will have routine checks and preventive maintenance tasks that must be done by a skilled maintenance person to keep the forklift in safe operating condition. Keep a record of this maintenance as well as any repairs that are made. A DOSH compliance officer assigned to investigate an accident involving a forklift will ask to see maintenance and repair records. If you do not have records, it will be impossible for you to prove any maintenance was done and may result in a citation.

When you replace parts, make sure they are equivalent to the original manufactured part.

Do not alter or eliminate any forklift parts or add any accessories such as additional counterweights or lifting attachments unless approved by the manufacturer in writing. Make any necessary changes to the load capacity plate and operating instructions.

## Safety in the Maintenance Area

To prevent injury or illness when doing maintenance on a forklift:

- Do not do repairs in an area with a potentially flammable or combustible atmosphere (Class I, II, or III as described previously).
- Make sure there is adequate ventilation to prevent accumulation of exhaust or gas fumes.
- Do not use flammable solvent to clean a forklift. Use a non-combustible (flash point above 100° F) solvent.
- Never get under a forklift supported only by a jack or under any part supported only by hydraulic pressure! Install jack stands or a secure block support.
- To prevent the forklift from accidentally being started; remove and keep control of the key or disconnect the battery while making repairs. If the electrical system will be serviced, you must disconnect the battery before starting repairs.

# Summary

---

A forklift is a powerful tool when used by a well-trained operator. It helps to move materials and can reduce the risk of back injury by eliminating the need to lift and carry items by hand.

However, the deaths of nearly 100 workers and 20,000 serious injuries a year show that a forklift can be dangerous.

To prevent your workplace from adding to these statistics:

- Use the appropriate forklift and attachments based on the driving location, size of load, and potential for hazardous atmosphere.
- Make sure that forklift operators are given formal instruction, hands-on training and periodic evaluation as required by DOSH regulations.
- Observe forklift operators in their daily work and take prompt corrective action to correct careless or unsafe operations.
- Maintain forklifts in safe condition free of defective or missing parts through daily visual checks and regular preventive maintenance.

## Operator's Daily Checklist: Gas or LPG Forklift

Check each item before the shift starts. Put a check in the box if the item is OK. Explain any unchecked items at the bottom and report them to a supervisor. Do not use an unsafe forklift! Your safety is at risk.

Forklift Serial Number: \_\_\_\_\_

Operator: \_\_\_\_\_

Hour Meter Reading: \_\_\_\_\_ Date: \_\_\_\_\_

✓	Visual Check
	Tires are inflated and free of excessive wear or damage. Nuts are tight.
	Forks and mast are not bent, worn, or cracked.
	Load back rest extension is in place and not bent, cracked, or loose.
	Overhead guard is in place and not bent, cracked, or loose.
	Attachments (if equipped) operate OK and are not damaged.
	Forklift body is free of excessive lint, grease, or oil.
	Engine oil is full and free of leaks.
	Hydraulic oil is full and free of leaks.
	Radiator is full and free of leaks.
	Fuel level is OK and free of leaks.
	Battery connections are tight.
	Covers over battery and other hazardous parts are in place and secure.
	Load rating plate is present and readable.
	Warning decals and operators' manual are present and readable.
	Seat belt or restraint is accessible and not damaged, oily, or dirty.
	Engine runs smooth and quiet without leaks or sparks from the exhaust.
	Horn works.
	Turn signal (if equipped) operates smoothly.
	Lights (head, tail, and warning) work and are aimed correctly.
	Gauges and instruments are working.
	Lift and lower operates smoothly without excess drift.
	Tilt operates smoothly without excessive drift or "chatter".
	Control levers are labeled, not loose or binding and freely return to neutral.
	Steering is smooth and responsive, free of excessive play.
	Brakes work and function smoothly without grabbing. No fluid leaks.
	Parking brake will hold the forklift on an incline.
	Backup alarm (if equipped) works.

## Operator's Daily Checklist: Electric Forklift

Check each item before the shift starts. Put a check in the box if the item is OK. Explain any unchecked items at the bottom and report them to a supervisor. Do not use an unsafe forklift! Your safety is at risk.

Forklift Serial Number: \_\_\_\_\_

Operator: \_\_\_\_\_

Hour Meter Reading: \_\_\_\_\_ Date: \_\_\_\_\_

✓	Visual Check
	Tires are inflated and free of excessive wear or damage. Nuts are tight.
	Forks and mast are not bent, worn, or cracked.
	Load back rest extension is in place and not bent, cracked, or loose.
	Overhead guard is in place and not bent, cracked, or loose.
	Attachments (if equipped) operate OK and are not damaged.
	Forklift body is free of excessive lint, grease, or oil.
	Hydraulic oil is full and free of leaks.
	Battery connections are tight.
	Covers over battery and other hazardous parts are in place and secure.
	Load rating plate is present and readable.
	Warning decals and operators' manual are present and readable.
	Seat belt or restraint is accessible and not damaged, oily, or dirty.
	Motor runs smooth without sudden acceleration.
	Horn works.
	Turn signal (if equipped) operates smoothly.
	Lights (head, tail, and warning) work and are aimed correctly.
	Gauges and instruments are working.
	Lift and lower operates smoothly without excess drift.
	Tilt operates smoothly without excessive drift or "chatter".
	Control levers are labeled, not loose or binding and freely return to neutral.
	Battery charge level is OK while holding full forward tilt.
	Steering is smooth and responsive, free of excessive play.
	Brakes work and function smoothly without grabbing. No fluid leaks.
	Parking brake will hold the forklift on an incline.
	Backup alarm (if equipped) works.



# We're Ready to Help!

...from 22 offices  
across the state.

*Call Your Local  
L & I Office to  
Schedule a No-Fee  
Safety and Health  
Consultation*

**T**he Department of Labor and Industries offers educational services and free, confidential safety and health consultations to employers in Washington.

During a consultation, L&I safety and health professionals examine your workplace and make recommendations on how to comply with WISHA standards.

Call the local L&I office nearest you for help putting together your company's safety and health program.

Aberdeen	(360)	533-8200
Bellevue	(425)	990-1400
Bellingham	(360)	647-7300
Bremerton	(360)	415-4000
Colville	(509)	684-7417
	Toll-free	1-800-509-9174
East Wenatchee	(509)	886-6500
	Toll-free	1-800-292-5920
Everett	(425)	290-1300
Kennewick	(509)	735-0100
Longview	(360)	575-6900
Moses Lake	(509)	764-6900
MountVernon	(360)	416-3000
Port Angeles	(360)	417-2700
Pullman	(509)	334-5296
	Toll-free	1-800-509-0025
Seattle	(206)	515-2800
Spokane	(509)	324-2600
	Toll-free	1-800-509-8847
Tacoma	(253)	596-3800
Tukwila	(206)	835-1000
Tumwater	(360)	902-5799
Vancouver	(360)	896-2300
Yakima	(509)	454-3700
	Toll-free	1-800-354-5423





# Forklift Training Facts\*

March 2005

\*Applies to all Powered Industrial Trucks covered by WAC 296-863



*A training program covering the general forklift information is available on the L&I Web site at: [www.LNI.wa.gov/Safety/TrainTools/Online/Courses/default.asp](http://www.LNI.wa.gov/Safety/TrainTools/Online/Courses/default.asp)*

Contact Consultation Services for further information:

Everett	425-290-1431
Tukwila	206-835-1146
Tacoma	253-596-3917
Tumwater	360-902-5472
E. Wenatchee	509-886-6570
Spokane	509-324-2543

## Answers to the Most-often Asked Questions about Forklift Training

*Learn more at: [www.LNI.wa.gov/Safety/Topics/AtoZ/Forklift/default.asp](http://www.LNI.wa.gov/Safety/Topics/AtoZ/Forklift/default.asp)*

### Must employees be trained? **Yes!**

All employees operating a forklift must be trained. The training consists of three elements: formal (general, classroom-type) training, practical (site-specific, hands-on) training and a visual evaluation of the operator's skill.

### Does training have to be documented? **Yes!**

The employer must keep a record of forklift training and the evaluation. The record includes the name of the operator, date of the training, date of evaluation and the name of the person(s) giving the training and evaluation.

### Does an employer have to hire a professional trainer to give the training? **No!**

Anyone who has the knowledge, training and experience to train and evaluate forklift operators can conduct the training.

### Does training from a previous employer count? **Yes! and No!**

Training received from a previous employer can meet the general, classroom-type training requirement, if such training was appropriate to the truck and working conditions encountered and if the operator was evaluated and found competent to operate the truck safely within three years. However, the current employer is still responsible for site-specific hands-on training for the specific forklift that the employee will be using. Additionally, the current employer is required to observe and evaluate the employee's ability to safely operate the forklift. Both the training and the evaluation have to be documented. *(Sample on back of this form.)*

### Can an employer develop their own training program? **Yes!**

An employer can develop their own program using, for example, WISHA Codes, *Forklift Safety Guide\*\**, videos, an owner's manual review and a hands-on training session. Additionally, the trainer would observe the operator and evaluate their ability to safely operate the forklift. *Topics required to be covered during training and evaluation are listed on the back of this fact sheet.*

### Is a license or certification required to operate a forklift? **No!**

There is no license or "certification" requirement for forklift operators. The requirement is that the operator receives the following training:

- General forklift operation and safety information *(topics listed on the back of this form)*
- Workplace-specific training, including a hands-on demonstration on the type of forklift the operator will actually be using *(topics listed on the back of this form)*
- An evaluation of the operator's skill and ability to operate the forklift safely  
And remember to document the training!

### Does the employee have to be evaluated after being trained? **Yes!**

After completing the classroom training and the hands-on training, the employee must demonstrate the skills learned. An evaluator designated by the employer must visually evaluate these skills. Additionally, all employees must be evaluated every three years to ensure that they are still operating the forklifts in a safe manner.

## These topics must be covered when training or evaluating a forklift operator.

*Employers may use this checklist to document that employees have been trained and/or evaluated in all the topics listed below.*

<b>General Forklift Topics:</b>	<b>Workplace-Specific Topics:</b>
Operating instructions, warnings and precautions for types of industrial truck the operator will be authorized to operate.	Surface conditions where the vehicle will be operated.
Differences between the forklift and an automobile.	Composition of loads to be carried and load stability.
Vehicle controls and instrumentation: Where they are located, what they do and how they work.	Load manipulation, stacking and unshackling.
Engine or motor operation.	Pedestrian traffic where the vehicle will be operated.
Steering and maneuvering.	Narrow aisles and other restricted places where the vehicle will be operated.
Visibility (including restrictions due to loading).	Hazardous (classified) locations where the vehicle will be operated.
Fork and attachment adaptation, operation and use limitations.	Ramps and other sloped surfaces that could affect the vehicle's stability.
Vehicle capacity.	Closed environments and other areas where insufficient ventilation or poor vehicle maintenance could cause a buildup of carbon monoxide or diesel exhaust.
Vehicle stability.	Other unique or potentially hazardous environmental conditions in the workplace that could affect safe operation.
Vehicle inspection and maintenance that the operator will be required to perform.	Hands-on demonstration using the type of vehicle that the operator will actually be using.
Refueling and/or charging and recharging of batteries.	Changes in workplace conditions that could affect safe operation (such as: new trenches, new worker access routes or new staging areas on construction sites).
Operating limitations.	
Other operating instructions, warnings or precautions listed in the operator's manual for the types of vehicle that the employee is being trained on.	

Name of Operator: \_\_\_\_\_

Date of Formal Training: \_\_\_\_\_ Name of Trainer: \_\_\_\_\_

Date of Practical Training: \_\_\_\_\_ Name of Trainer: \_\_\_\_\_

Date of Evaluation: \_\_\_\_\_ Name of Evaluator: \_\_\_\_\_







Division of Occupational Safety and Health  
Department of Labor and Industries  
P.O. Box 44640  
Olympia, WA 98504-4641

**Learning the safe way  
to operate a forklift  
may save your life**